

MATIERE: Bois resineux: sapin, pin epicea.
 FINITION: Lasure exterieure.



le bois c'est essentiel

www.bois.com

PLAN D'ENSEMBLE

REFERENCE PLAN: TR-001

PROJET: TABLE DE REMPOTAGE

ECHELLE: 1/10

FORMAT: A3

DATE: 23/05/2007



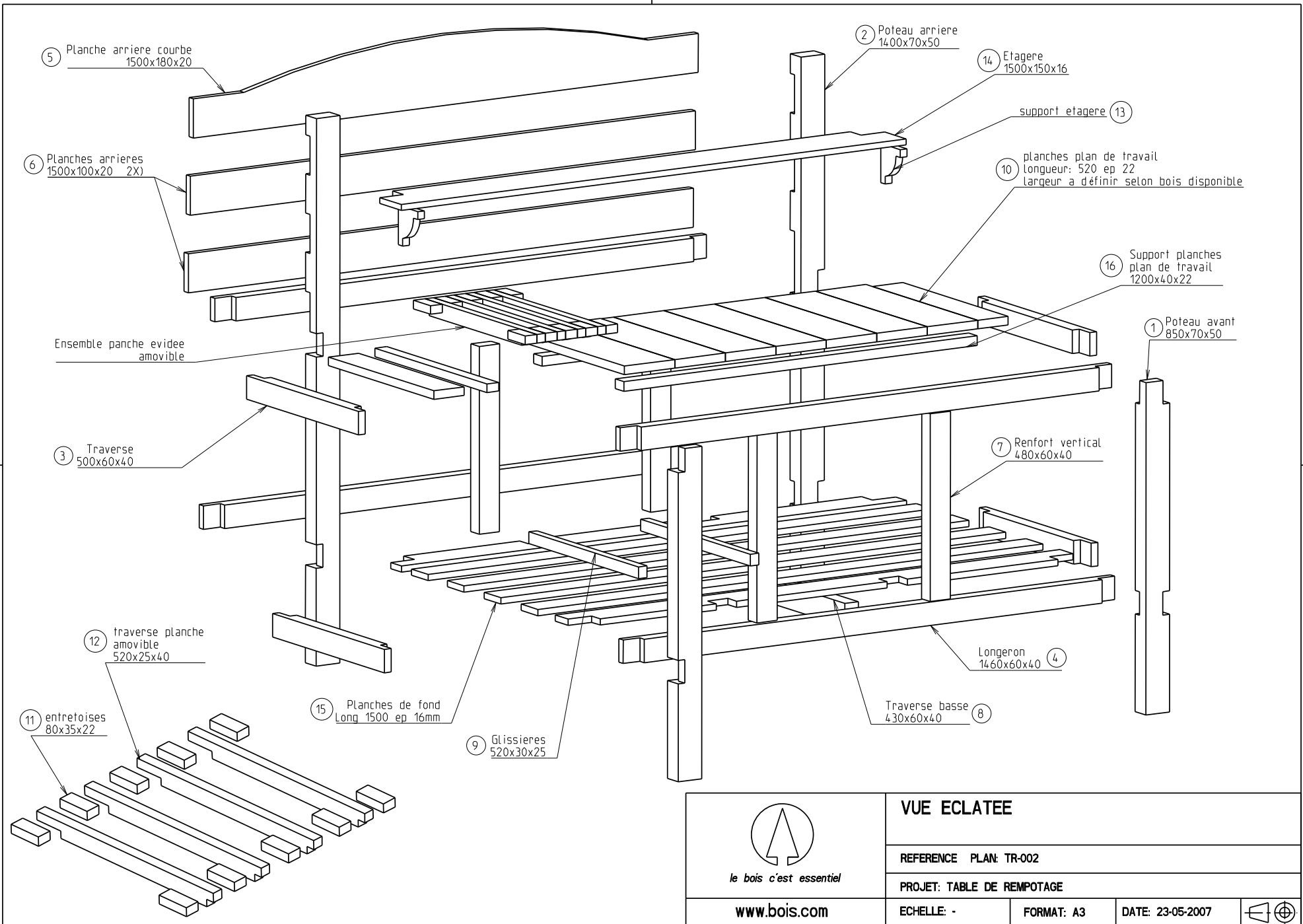



PLANCHE EVIDEE AMOVIBLE



le bois c'est essentiel

www.bois.com

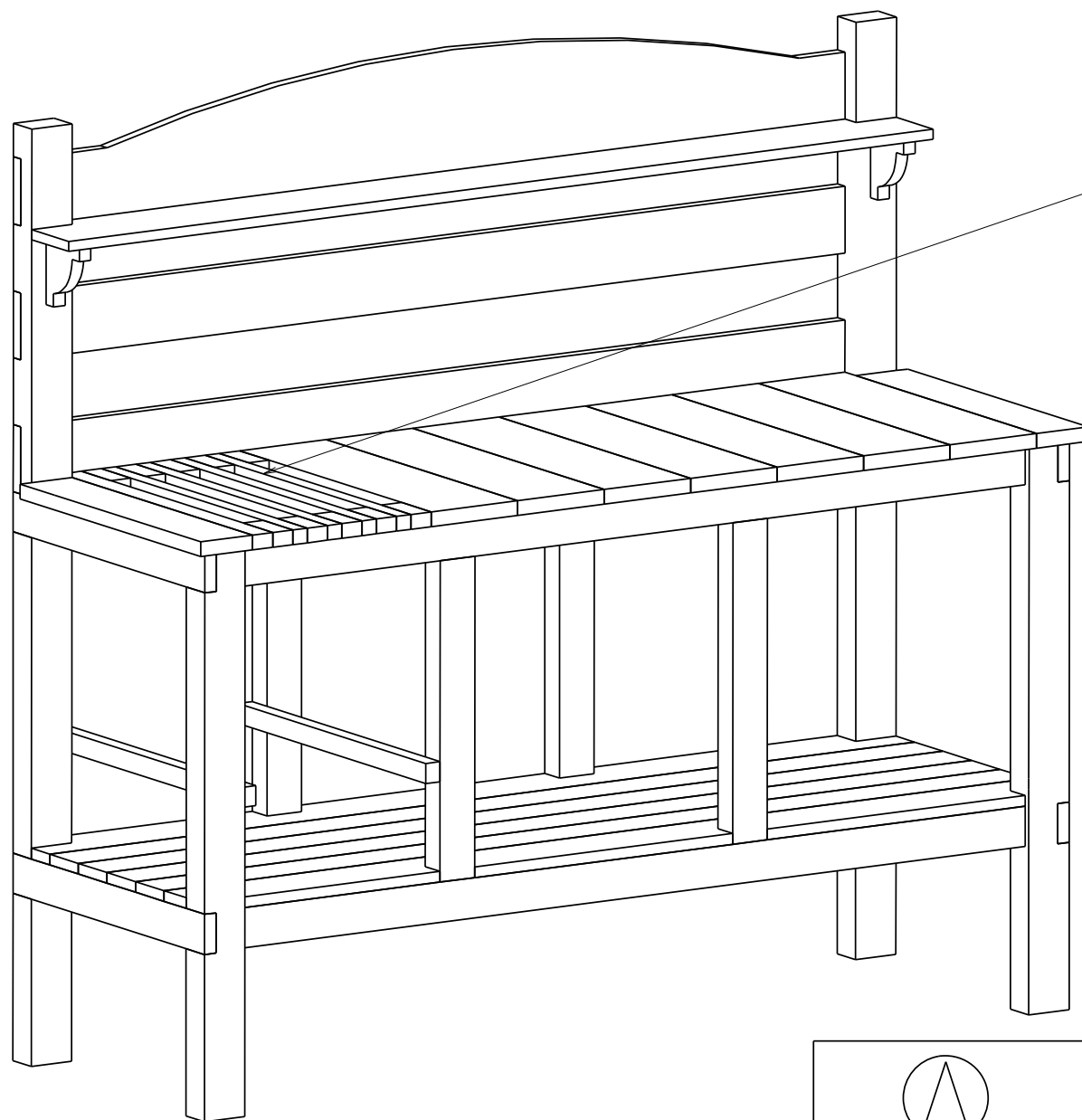
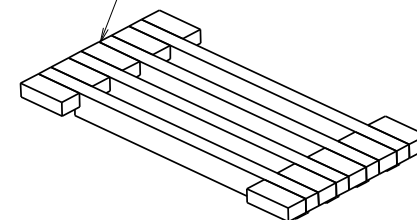
VUE D'ENSEMBLE

REFERENCE PLAN: TR-003

PROJET: TABLE DE REMPOTAGE

ECHELLE: -

FORMAT: A3

DATE: 23-05-2007

